

Quantitative Evaluation of Iron Loss Reduction Effect by Multilevel Inverters for IPMSM Drives

Taichi Kimura^{1*}, Hirotaka Kato¹, Yuki Nakata¹, Hiroki Watanabe¹, Jun-ichi Itoh¹
¹ Nagaoka University of Technology, Nagaoka, Japan
 *s243115+kimura@stn.nagaokaut.ac.jp

Abstract— This paper quantitatively evaluates the iron-loss reduction effect obtained by applying multilevel inverters to an interior permanent magnet synchronous motor (IPMSM) drive. A two-level inverter and 3-, 5-, and 7-level flying-capacitor converters (FCCs) are compared using an equivalent switching frequency. Simulation current waveforms are used for iron-loss analysis. When the equivalent switching frequency is matched, the 7-level FCC reduces the current total harmonic distortion (THD) by 66.7% and the iron loss by 23.8% compared with the two-level inverter. To obtain an equivalent iron-loss reduction by only increasing the switching frequency, the two-level inverter requires a switching frequency 22.4 times the equivalent switching frequency of the 7-level FCC.

Keywords—Flying-capacitor Converter, Iron loss, IPMSM, Multilevel inverter

I. INTRODUCTION

GaN power devices have attracted attention for high-efficiency EV drive systems. Because GaN FETs have low on-state resistance and high-speed switching capability, they are expected to improve system efficiency and contribute to downsizing and weight reduction of power converters [1].

IPMSMs, which are commonly used for EV traction applications, are designed with low armature inductance and large current to achieve high output power at high speed under a limited battery voltage. However, PWM current ripple increases, which may increase harmonic iron loss in the motor. Two typical methods for reducing current ripple are to increase the number of voltage levels and to increase the switching frequency. The former increases the number of components, whereas the latter increases inverter switching loss. Although the iron-loss reduction effect of multilevel inverters has been experimentally reported [2], the relative effectiveness of multilevel configurations and high-frequency switching has not been sufficiently discussed. From a practical viewpoint, high-frequency switching can be applied without changing the two-level inverter topology. Therefore, when comparing these two methods, both the switching frequency required to obtain an equivalent iron-loss reduction and the inverter loss under that condition should be considered.

In this paper, these current-ripple reduction methods are compared based on the equivalent switching frequency and the switching frequency required for the same iron loss. The results show that multilevel operation using GaN power devices gives a larger iron-loss reduction than high-frequency operation and requires a lower switching frequency.

II. MOTOR AND INVERTER MODELS

A. Motor Model

Table I lists the parameters of the IPMSM model used in the analysis. The analysis is based on the IEEJ D-model [3].

To clarify the reduction effect of harmonic iron loss, the rated speed, rated output, and dc-link voltage were modified. The motor was driven by vector control in the simulation, and the steady-state current waveforms were exported as a table for the iron-loss analysis.

B. Inverter Model

Fig. 1 shows the circuit configurations of the two-level inverter and the n -level flying-capacitor converter (FCC) used in the simulation. The two-level inverter is driven by triangular-carrier comparison PWM, whereas the n -level FCC is driven by phase-shifted-carrier PWM. In this study, $n = 3, 5, \text{ and } 7$ are analyzed.

Because the carrier frequency and the actual number of switching transitions are different in an n -level FCC, the equivalent switching frequency is used as the evaluation index. This index enables the iron-loss reduction effect of the smaller motor-side voltage ripple in the FCC to be evaluated under the same voltage-ripple frequency condition. The equivalent switching frequency of the n -level FCC is defined as

$$f_{eq_FCC} = (n-1)f_c \quad (1)$$

where f_c is the carrier frequency. The iron loss is analyzed while f_c and f_{eq_FCC} are changed, and the reduction effects of multilevel operation and high-frequency operation are quantitatively compared.

Table I. Motor parameters.

Rated power	1.1kW	Winding resistance	0.814Ω
Base speed	6000rpm	dq-axis inductance	8.9mH, 24.2mH
Rated torque	1.85Nm	Magnetic flux	147mWb
Rated current	3A _{rms}	Iron core	50A350
DC-link voltage	480V	Magnet	Remanence 1.25 T
Number of poles	2		Relative permeability 1.05

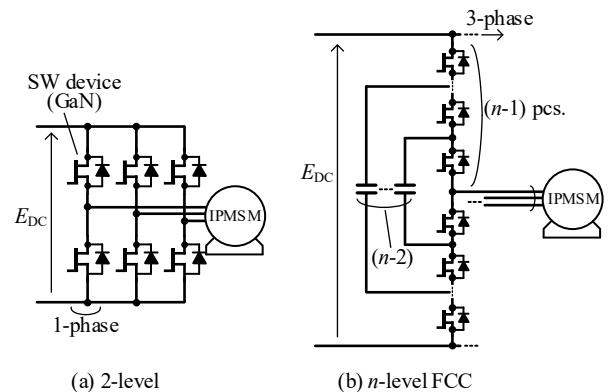

Fig. 1. Circuit configurations.

III. ANALYSIS RESULTS

A. Effect of Multilevel Operation

Fig. 2 shows the analyzed operating points on the N-T map and the calculated iron loss when the number of inverter levels is changed. The operating points are defined by speeds of 0.5 p.u., 1 p.u. (rated), and 2 p.u. and torques of 0.1 p.u., 0.5 p.u., and 1 p.u. (rated).

When the carrier frequency of the two-level inverter is fixed at 5 kHz, the FCC reduces the iron loss by increasing the number of voltage levels. In particular, at operating point 3, the 7-level FCC reduces the iron loss by 25.4% compared with the two-level inverter. A similar iron-loss reduction is obtained even when the equivalent switching frequency is matched. At operating point 3, the 7-level FCC reduces the iron loss by 13.4% and the current THD by 51.8%. The largest reduction ratio is obtained at operating point 1, where the iron loss and current THD are reduced by 23.8% and 66.7%, respectively.

The reduction is attributed to the decrease in the applied voltage step size. Although the switching-frequency component applied to the motor terminals does not change, the voltage amplitude associated with each switching transition becomes smaller as the number of levels increases. Consequently, the variation in flux density ΔB is reduced and the harmonic iron-loss component is suppressed. This effect is especially clear under operating conditions in which the harmonic component occupies a large part of the total iron loss.

On the other hand, the improvement becomes limited as the number of levels increases. For example, the difference between the 5-level and 7-level FCCs is small at operating point 6. This is because multilevel operation can reduce the harmonic iron loss, whereas the fundamental iron loss remains almost unchanged. Therefore, the total reduction ratio depends on the operating point and on the ratio of harmonic iron loss to total iron loss.

B. Effect of High-Frequency Operation

Fig. 3 shows the calculated iron loss and inverter loss when the switching frequency is increased. The inverter loss includes the conduction loss and switching loss of the switching devices. The analysis is performed at operating point 3, where the iron-loss reduction shown in Fig. 2 is the largest. In the inverter-loss analysis, the parameters of a 650-V GaN FET (Infineon IGLT65R110D2) were used. The on-state resistance $R_{DS(on)}$ and output charge Q_{oss} were 110 m Ω ($T_J = 25^\circ\text{C}$) and 18 nC (at 400V), respectively. In Fig. 3, the switching frequency required for the two-level inverter is evaluated so that the iron loss becomes almost equal to that obtained by the n -level FCC at a carrier frequency of 5 kHz.

The iron loss of the two-level inverter decreases as the switching frequency increases. To obtain an iron-loss reduction equivalent to the 3-, 5-, and 7-level FCCs at $f_c = 5$ kHz, the required switching frequency of the two-level inverter is 25.3 kHz, 561 kHz, and 673 kHz, respectively. For the 7-level case, this corresponds to 22.4 times the equivalent switching frequency of the FCC. Thus, a simple increase in switching frequency requires a much higher operating frequency than the multilevel approach to obtain the same iron-loss reduction. However, the increased number of switching events increases the switching loss of the two-level inverter. As a result, the total loss, including the motor iron

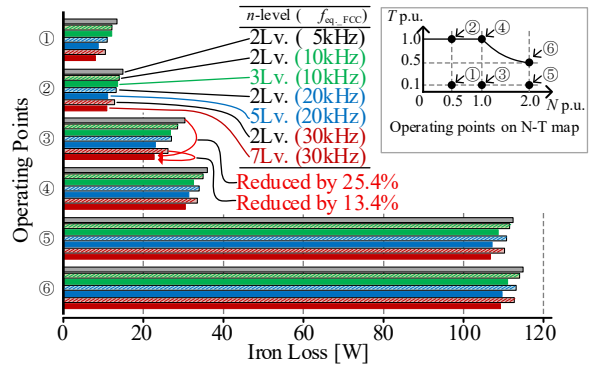

Fig. 2. Iron loss analysis results for different inverter levels.

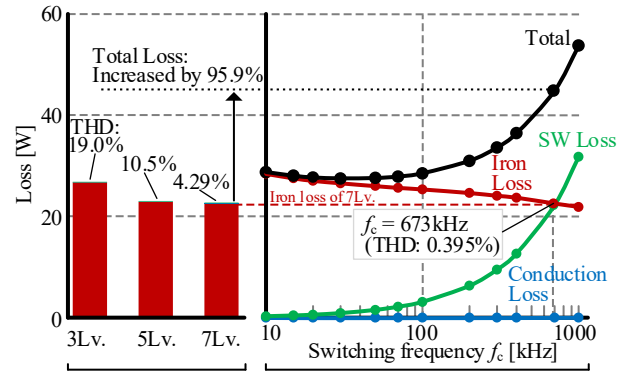

Fig. 3. Iron loss and inverter loss analysis results when switching frequency is changed.

loss and inverter loss, increases by 95.9% compared with the 7-level FCC.

In terms of current harmonics, when the switching frequency of the two-level inverter is adjusted so that its iron loss becomes equal to that of each FCC level, the THD of the two-level inverter is 44.6%, 91.6%, and 90.8% lower than those of the 3-, 5-, and 7-level FCCs, respectively. This means that the same THD does not always give the same iron loss. In the multilevel case, the current spectrum is more widely distributed, and the amplitude of the switching-frequency component becomes smaller, resulting in lower harmonic iron loss.

IV. CONCLUSIONS

When the switching frequency of the two-level inverter is matched to the equivalent switching frequency of the 7-level FCC, multilevel operation reduces the iron loss by 23.8%. To obtain the same reduction only by high-frequency operation, the two-level inverter requires a switching frequency 22.4 times the equivalent switching frequency of the 7-level FCC. Therefore, multilevel operation is more effective for iron-loss reduction than high-frequency operation under the same equivalent switching-frequency condition. Future work will experimentally evaluate the effect of multilevel operation.

REFERENCES

- [1] T. M. Jahns and H. Dai, "The past, present, and future of power electronics integration technology in motor drives," in CPSS Transactions on Power Electronics and Applications, vol. 2, no. 3, pp. 197-216, Sept. 2017.
- [2] H. Obara and Y. Sato, "Experimental Investigation on Reduction of Harmonic Iron Losses by Using Multilevel Inverters," Proceedings of the 2013 Institute of Electrical Engineers of Japan (IEEJ) Industry Applications Society Conference, No. 1-82, pp. I_393-I_398, 2013.
- [3] IEEJ-Technical Report, No.1244, 2012.